

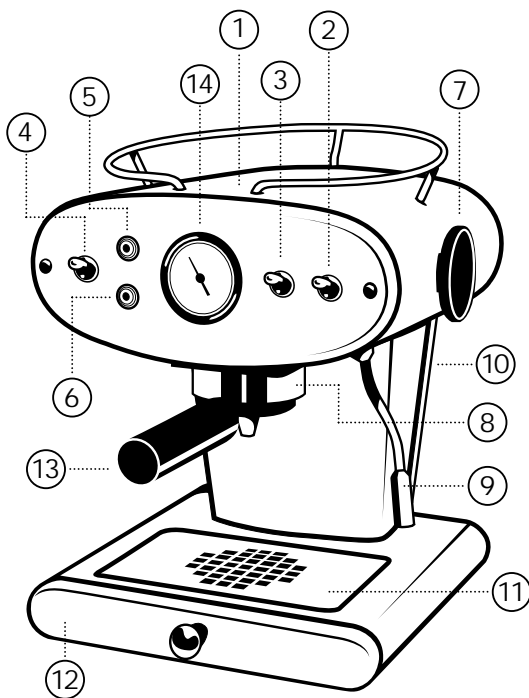

ESPRESSO MAKER WITH PUMP  
DESIGN BY LUCA TRAZZI

Instruction manual  
Manuale di istruzioni  
Bedienungsanleitung  
Manual de instrucciones  
Manuel d'instructions  
Manual de instruções





- GB 1 Steel cup warmer
- 2 Steam switch
- 3 Coffee switch
- 4 On/Off switch (I/O)
- 5 On/Off pilot light
- 6 Right temperature pilot light
- 7 Steam valve
- 8 Filter- holder housing
- 9 Steam outlet (Cappuccino)
- 10 Cold water tank
- 11 Drip grill
- 12 Drip plate
- 13 Filter-holder
- 14 Thermometer
- 15 Intake pipe
- 16 Plate
- 17 Air absorption hole

- D 1 Tassenwärmer aus Stahl
- 2 Wasserdampfschalter
- 3 Kaffeeschalter
- 4 Ein/Aus Schalter I/O
- 5 Betriebslampe
- 6 Temperaturkontrolllampe
- 7 Dampfventil
- 8 Brühkopf
- 9 Dampfaustrittsrohr (Cappuccino)
- 10 Kaltwasserbehälter
- 11 Abtropfgitter
- 12 Abtropfschale
- 13 Filterträger
- 14 Temperaturmesser
- 15 Saugschlauch
- 16 Typenschild
- 17 Lufteinlass beim Dampfrohr

- I 1 Scaldatazze in acciaio
- 2 Interruttore vapore
- 3 Interruttore caffè
- 4 Interruttore avviamento (I/O)
- 5 Spia luminosa avviamento
- 6 Spia luminosa temperatura
- 7 Valvola vapore
- 8 Alloggio porta-filtro
- 9 Tubo uscita vapore (cappuccino)
- 10 Deposito acqua fredda
- 11 Reticella sgocciolio
- 12 Vassoio sgocciolio
- 13 Portafiltro
- 14 Termometro
- 15 Tubo di aspirazione acqua
- 16 Placca
- 17 Foro di aspirazione aria

- E 1 Calienta tazas de acero
- 2 Interruptor vapor
- 3 Interruptor café
- 4 Interruptor puesta en marcha I/O
- 5 Piloto indicador puesta en marcha
- 6 Piloto temperatura ideal
- 7 Válvula vapor
- 8 Alojamiento porta-filtro
- 9 Tubo salida vapor (cappuccino)
- 10 Depósito de agua fría
- 11 Rejilla de goteo
- 12 Bandeja de goteo
- 13 Porta-filtro
- 14 Termometro
- 15 Tubo de aspiración
- 16 Placa
- 17 Orificio de absorción de aire

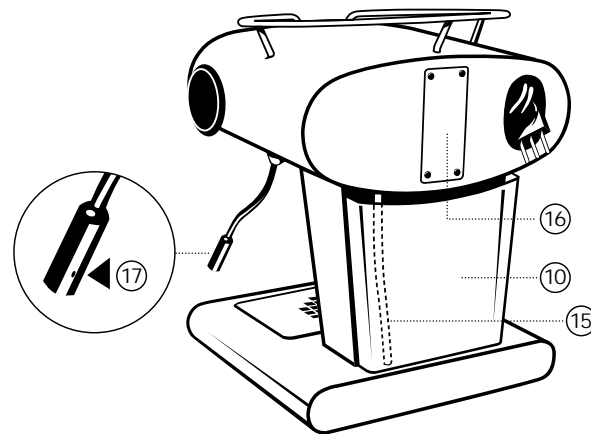

E.S.E. Serving

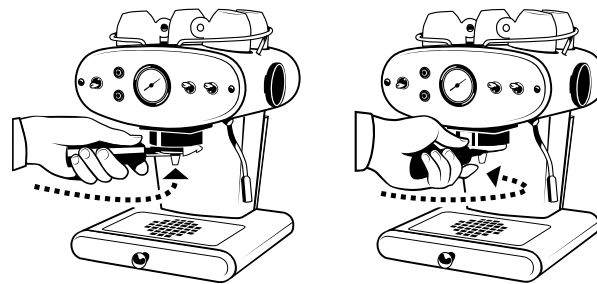
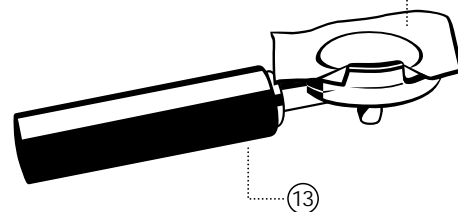

- F 1 Chauffe-tasses en acier
- 2 Interrupteur vapore
- 3 Interrupteur café
- 4 Interrupteur mise en marche I/O
- 5 Voyant indicateur mise en marche
- 6 Voyant température idéale
- 7 Soupape vapore
- 8 Logement porte-filtre
- 9 Tuyau sortie vapore (Cappuccino)
- 10 Réservoir d'eau froide
- 11 Grille d'égouttement
- 12 Plateau d'égouttement
- 13 Porte-filtre
- 14 Thermomètre
- 15 Conduit d'aspiration
- 16 Plaque
- 17 Trou d'absorption d'air

- P 1 Acquecedor de aço para chávenas
- 2 Botão vapor
- 3 Interruptor café
- 4 Interruptor funcionamento I/O
- 5 Piloto indicador funcionamento
- 6 Piloto temperatura ideal
- 7 Válvula vapor
- 8 Alojamento porta-filtro
- 9 Tubo saída vapor (cappuccino)
- 10 Depósito de agua fría
- 11 Grelha de gotejamento
- 12 Bandeja de gotejamento
- 13 Filtro
- 14 Termómetro
- 15 Tubo de aspiração
- 16 Placa
- 17 Furo de absorção do ar



X1 is a Francis Francis!  
production powered by  
Magic L'Espresso - Spain

Design by  
Luca Trazzi - Milan

It should be pronounced the way a mother, lovely disturbed by finding her little child hands and mouth black of stolen chocolate, would say: "Fraaaanics Fraaaancis!" her right hand straight moving like a saw, an expression she would like to be serious but is definitely unable to hold the overwhelming smile that will turn this little tragedy into a kiss. Because this, is Francis Francis!. It's the child within ourselves that we constantly love, the child that make us smile, laugh, enjoy. So, if someone asked himself what's that child in the brand name, it's just the best part of all of us. And Francis Francis! - with all his products - just wants to express this little childish sympathy, able to let you smile even when you think you are not in the mood.

**GB** IMPORTANT  
SAFEGUARDS

*When using electrical appliances, basic safety precautions should always be followed, including the following:*

1. Read all instructions.
2. Do not touch hot surfaces. Use handles or knobs.
3. To protect against fire, electric shock and injury to persons do not immerse cord, plugs or machine in water or other liquid.
4. Close supervision is necessary when any appliance is used by or near children.
5. Unplug from power socket when not in use and before cleaning. Allow to cool before putting on or taking off parts and before cleaning the appliance.
6. Do not operate any appliance with a damaged cord or plug or after the appliance malfunctions, or has been damaged in any manner. Return appliance to the nearest authorised service facility for examination, repair, or adjustment.
7. The use of accessory attachments not recommended by the appliance manufacturer may result in fire, electric shock, or injury to persons.
8. Do not use outdoors.
9. Do not let cord hang over edge of table or counter, or touch hot surfaces.
10. Do not place on or near a hot gas or electric burner, or in a heated oven.
11. Do not use appliance for anything other than its intended use.
12. SAVE THESE INSTRUCTIONS.

**I** IMPORTANTI MISURE  
DI SICUREZZA

*Nell'utilizzo di apparecchiature elettriche devono essere sempre osservate le seguenti misure di sicurezza:*

1. Leggere attentamente le istruzioni
2. Non toccare mai una superficie calda. Usare manici o pulsanti.
3. Per proteggersi dal fuoco, scosse elettriche o lesioni non immergere il cavo, la spina o in acqua o altro liquido.
4. Se l'apparecchio viene utilizzato da bambini o vicino a bambini, sorvegliare attentamente.
5. Disinserire la spina quando l'apparecchio non viene utilizzato o quando se ne esegue la pulizia. Lasciar raffreddare prima di aggiungere o levare parti accessorie e prima della pulizia.
6. Non utilizzare un apparecchio se il cavo o la spina sono danneggiati, o se l'apparecchio mostra segni di cattivo funzionamento oppure se ha subito qualche danno. Riportare l'apparecchio al concessionario autorizzato più vicino per controlli o riparazioni.
7. L'utilizzo di accessori non raccomandati dal produttore può provocare incendi, scosse elettriche o lesioni alle persone.
8. Non utilizzare all'esterno.
9. Non lasciare penzolare il cavo da tavoli o banconi, impedito che esso venga a contatto con superfici calde.
10. Non appoggiate l'apparecchio su fornelli elettrici o a gas, o dentro un forno caldo.

11. Non utilizzate l'apparecchio per scopi diversi da quello previsto.
12. CONSERVATE QUESTE ISTRUZIONI.

**D** WICHTIGE  
SICHERHEITSHINWEISE

1. Lesen Sie alle Bedienungshinweise.
2. Berühren Sie keine heißen Flächen. Griffe und Knöpfe benutzen.
3. Um Feuer, elektrischen Schlag und Verletzungen zu vermeiden, nie das Kabel oder den Stecker in Wasser oder andere Flüssigkeiten eintauchen.
4. Wenn die Maschine in der Nähe von Kindern in Gebrauch ist, muss die Maschine überwacht werden.
5. Stecker aus der Steckdose ausziehen, wenn die Maschine länger nicht benutzt wird oder bei Reinigung.
6. Die Maschine nie mit einem beschädigten Kabel oder Stecker benutzen, wenn die Funktionsweise Fehler aufweist, oder wenn die Maschine beschädigt wurde. Senden Sie die Maschine an die nächste Service-Stelle zur Überprüfung, Reparatur oder Anpassung ein.
7. Der Gebrauch von Zusatzgeräten, die nicht vom Hersteller empfohlen sind, können zu Feuer, Elektrischem Schlag oder Verletzung von Personen führen.
8. Nicht im Freien verwenden.
9. Vergewissern Sie sich, dass das Kabel nicht über die Kante (von Küchenabdeckung oder Tisch) hängt und lassen Sie das Kabel keine heißen

- Oberflächen berühren.
10. Maschine nicht auf oder nahe an Gas- oder Elektrobrenner stellen; nicht in den heißen Ofen stellen.
  11. Maschine nur für den in der Bedienungsanleitung beschriebenen Zweck benutzen.
  12. BEWAHREN SIE DIESE BEDIENUNGSANLEITUNG AUF.

**E** IMPORTANTES  
MEDIDAS DE  
SEGURIDAD

*Al usar todo aparato eléctrico, hay que respetar las siguientes medidas de seguridad:*

1. Lea atentamente las instrucciones.
2. Nunca toque una superficie caliente. Utilice las empuñaduras o los botones.
3. Para protegerse contra el fuego, contra las descargas eléctricas y las lesiones, en general, no sumerja el cable, el enchufe, ni en el agua, ni en ningún otro líquido.
4. Si los niños utilizan el artefacto, o bien, si se usa cerca de los mismos, vigile con suma atención.
5. Desenchufe el aparato, cuando deja de usarlo y antes de proceder a limpiarlo. Deje que se enfríe antes de añadirle o quitarle los accesorios y antes de limpiarlo.
6. Nunca utilice un aparato, cuyo cable o enchufe están estropeados; si el mismo funciona mal o si se ha producido algún desperfecto. Lleve el aparato al concesionario autorizado de su zona para que lo controle o lo arregle.
7. El empleo de accesorios



E.S.E.  
(Easy Serving Espresso)

**GB** The X1 espresso machine uses the EASY SERVING ESPRESSO (E.S.E.) system: for it to operate properly it is necessary to use the E.S.E. servings, which are easily recognizable from the brand name printed on the packets, the same one that is shown on the espresso machines. The E.S.E. system guarantees a series of benefits: the quality of the espresso coffee always remains constant, irrespective of the consumer's skill in making it. It is easy to use and very fast, and the system is extremely easy to clean. It is very important that you keep the E.S.E. servings in a closed container in a dry, well-aired environment.

**I** La macchina per espresso X1 impiega il sistema EASY SERVING ESPRESSO (E.S.E.): per un corretto funzionamento è necessario utilizzare i serving E.S.E., facilmente riconoscibili dal marchio impresso sulle confezioni, lo stesso che si ritrova anche sulle macchine per espresso. Il sistema E.S.E. garantisce una serie di vantaggi: la qualità del caffè espresso rimane sempre costante indipendentemente dall'esperienza del consumatore nel prepararlo, l'impiego è facile e molto veloce, la pulizia del sistema è estremamente semplice. E' fondamentale conservare i serving E.S.E. in un recipiente chiuso in ambiente secco e ventilato.

**D** Die Espresso-Maschine X1 arbeitet mit dem System EASY SERVING ESPRESSO (E.S.E.): Für ein einwandfreies Funktionieren ist es notwendig, die Portionen E.S.E. zu verwenden. Die Portionen erkennen Sie am E.S.E. Markenzeichen auf der Kaffeeverpackung. Dieses Markenzeichen finden Sie ebenfalls auf der Verpackung der Espresso-Maschinen. Das System E.S.E. garantiert eine Reihe von Vorteilen: Die Qualität des Espresso bleibt immer konstant, unabhängig von der Erfahrung der zubereitenden Person. Die Verwendung von Portionen ist einfach und sehr schnell, die Reinigung der Maschine äusserst einfach. Es ist sehr wichtig, dass die E.S.E. Portionen in einem geschlossenen Behälter trocken und ohne Fremdgerüche aufbewahrt werden.

**E** La máquina de café exprés X1 se utiliza con el sistema EASY SERVING ESPRESSO (E.S.E.). Para que la misma funcione correctamente, es preciso utilizar los servings E.S.E. Los reconocerá fácilmente mediante la marca impresa en los envases, que es la misma que se aprecia en las máquinas de café exprés. El sistema E.S.E. garantiza una serie de ventajas: la calidad del café exprés permanece siempre constante, independientemente de la pericia del consumidor, a la hora de prepararlo; es fácil de usar y muy rápido; el sistema es muy sencillo de limpiar. Es fundamental que conserve los serving E.S.E.

en un recipiente cerrado, en un ambiente seco y ventilado.

**F** La cafetière pour espresso X1 utilise le système EASY SERVING ESPRESSO (E.S.E.): pour qu'elle fonctionne correctement, il faut donc employer les serving E.S.E. que l'on reconnaîtra aisément à la marque imprimée sur leur emballage et qui figure sur la cafetière elle-même. Le système E.S.E. présente toute une série d'avantages: il garantit une qualité de café espresso constante, indépendamment de l'habileté du consommateur à le préparer, il est d'utilisation rapide et facilite le nettoyage de la machine. IMPORTANT: les serving E.S.E. doivent être conservés dans un récipient fermé et dans un lieu sec et bien aéré.

**P** A máquina para café espresso X1 utiliza o sistema EASY SERVING ESPRESSO (E.S.E.): para o correcto funcionamento é necessário utilizar o serving E.S.E. que se reconhece facilmente pela marca gravada nas confeções, o mesmo que se encontra nas máquinas para café espresso. O sistema E.S.E. garante uma série de vantagens: a qualidade do café espresso permanece sempre constante independentemente da prática do consumidor em prepara-lo, o uso é fácil e muito rápido, a limpeza do sistema é extremamente simples. É fundamental conservar o serving E.S.E. fechado num recipiente num ambiente seco e ventilado.

## INSTRUCTION MANUAL

## General Rules for Using the Machine

The machine must be kept clean by frequently rinsing the drawer (12), the filter-holder (13) and the tank (10), the steam outlet pipe (9) and the air absorption hole (17).

VERY IMPORTANT: never immerse the machine in water or put it in a dishwasher.

The water contained in the tank (10) must be regularly changed. After changing the water, check that the intake pipe (15) is positioned inside the tank (10).

It is recommended that every three months you use a mixture specially designed for espresso machines to remove limescale. To enjoy a perfect espresso, you are advised to keep the cups warm using the cup-warmer (1) incorporated in the machine.

## Operating the Machine

## Installation

A) Check that the voltage of the supply current is correct by looking on the plate (16): if so, connect the machine to the socket.

B) Half-fill the tank with cold water (10), ensuring that the intake pipe (15) is immersed in the water. Place a recipient under the filter-holder (8).

Turn on the general switch (4) and make the water circulate around the internal circuit by turning on the coffee switch (3).

C) Fill the tank again (10), checking that the intake pipe (15) is immersed in the water.

How to obtain the first coffee after installing (or turning off) the machine

To make sure the machine is in the ideal condition to make a perfect espresso, follow the instructions below:

D) Turn on the main switch (4) and make sure the starting pilot light (5) is on: if the temperature of the machine is not sufficiently high, the temperature pilot light (6) will come on.

Place the filter-holder (13) in its housing. Wait for the temperature pilot light (6) to go off. Place a cup under the filter-holder (13) and turn on the coffee switch (3). Allow the hot water to come out. Empty the hot water from the cup.

*At this point the machine and the cup are ready for a perfect espresso.*

E) Take out an E.S.E. serving and place it in the filter-holder (13) with the printed side facing downwards.

F) Place the filter-holder (13) in its housing, rotating until it is firmly fitted making a good seal.

G) Make the coffee by turning on the switch (3): once you have the desired quantity of coffee (extra strong or mild), turn off the switch (3).

H) Remove the filter-holder (13) from its housing, by repeating the operation described in point F) in reverse. Dispose of the used E.S.E. serving.

Subsequent preparation of other coffees

I) To make other coffees, repeat operations E to H.

How to obtain steam (making a cappuccino)

J) Ensure that there is no serving in the filterholder. With the steam valve (7) in a closed position, turn on the steam switch (2). If the temperature pilot light (6) was not already on, this operation will make it come on.

K) After turning off the temperature pilot light (6), open the steam valve (7) slightly, by turning anti-clockwise, and release the residual water from the pipe (9) until the steam arrives. When steam starts to come out, close the valve (7).

L) Place a recipient with the milk under the steam-cappuccino outlet pipe (9) so that part of it is immersed. Then open the steam valve (7) to obtain the steam required. A special hole at the side of the nozzle makes it possible for a small portion of air to be absorbed, which, mixing with the milk, transforms it into foam for cappuccino. If this does not occur, alter the position of the recipient so that the air absorption hole (17) is not covered by the milk.

It is preferable to use very cold milk.

Turn off the steam switch (2).

If you note a reduction in the supply of steam, close the steam valve (7) and turn on the coffee switch (3) until

water comes out of the filter-holder (8). Then repeat steps K and L.

M) It is very important to avoid making an espresso immediately after the steam is supplied, as the machine is still too hot.

To reduce the temperature of the machine quickly and obtain a perfect espresso, follow the instructions below:

- Ensure that there is no serving in the filterholder.
- Turn on the coffee switch (3) and put a recipient under the filter-holder (13) enabling the hot water to come out until the temperature pilot light comes on (6).
- Turn off the coffee switch (3), thus interrupting the flow of water and wait for the temperature pilot light to go off: the machine is now again ready to make another espresso.

THE MANUFACTURER RESERVES THE RIGHT TO MAKE MODIFICATIONS OR IMPROVEMENTS WITHOUT PRIOR NOTICE.  
TECHNICAL CHARACTERISTICS:  
VOLTAGE: 220/230 V (110/120 V US - 110 V J)  
POWER: 1.050 W